

UNDervOLTAGE TRIP DEvICE FOR TYPE DBN-40 OR DBN-60 CIRCUIT BREAKERS (NAVY TYPE ACB 640 OR ACB 1600)

FUNCTION

The function of this unit is to trip the circuit breaker when the line voltage drops below the nominal transient voltage level. The device is mounted on the front shelf of the circuit breaker and operates directly on the main trip bar to open the circuit breaker without intentional time delay on any condition from no voltage to drop out voltage rating. The device is automatically reset; that is, after it has dropped out and tripped the circuit breaker on reduced voltage, it will reset by the breaker action.

CHARACTERISTICS

<u>Nominal Voltage</u>	<u>Operating Range</u>	<u>Pickup and Seal Volts</u>	<u>Dropout Voltage</u>
450 A.C., 60 cycle	360-500	360 Min.	290 Max. & 45 Min.
250 D.C.	175-355	150 Min.	150 Max. & 25 Min.

The units are designed to withstand a minimum of 7500 operations and each device is furnished with two leads 24 inches long. The coil and connecting leads are fully insulated without exposed terminals or connections.

OPERATION

The following operating cycle is performed when a closed circuit breaker with its undervoltage device energized at nominal voltage is subjected to a reduced voltage condition:

At nominal rated voltage the armature (104) is held in place between the pole faces against the torque of torsion spring (107) by the magnetic force. Roller (109) rests on the cam surface (105) and maintains lever (110) away from trip bar (117).

As the transient voltage falls below the drop out voltage the armature spring (107) rotates the armature and cam assembly clockwise until roller (109) is rotated into the cam slot by spring (115) and simultaneously the circuit breaker is tripped.

As the circuit breaker opens, the cross bar (116) rotates reset lever (112) counter-clockwise about pin (113). The reset lever (112) rotates spring release (111) clockwise about pin (120) and removes the spring load on the armature-cam assembly. The reset-lever also rotates the trip lever (110) clockwise and removes the roller (109) out of the slot.

The following operating cycle is performed when the circuit breaker is being closed with the undervoltage device energized at nominal voltage after opening because of a low voltage condition:

After the line voltage restores to its nominal value the magnetic force aligns the armature with the pole faces. Then as the circuit breaker is closed the cross bar (116) releases the reset lever (112) and the trip lever (110). The trip lever (110) is rotated counter-clockwise by spring (115) until roller (109) rests on the cam surface.

LEADS 24" LONG

- 100 FRAME
- 101 COVER
- *102 COIL
- 103 LAMINATION ASSEMBLY
- 104 ARMATURE
- 105 CAM
- 106 PIN
- *107 ARMATURE SPRING
- 108 PIN
- 109 ROLLER
- 110 TRIP LEVER
- 111 SPRING RELEASE
- 112 RESET LEVER
- 113 PIN
- *114 RESET SPRING
- *115 TRIP SPRING
- 116 CROSS BAR
- 117 TRIP BAR
- 118 PIN
- 119 PIN
- 120 TRUARC RING
- *121 TRUARC RING
- *122 TRUARC RING

* REPAIR PARTS

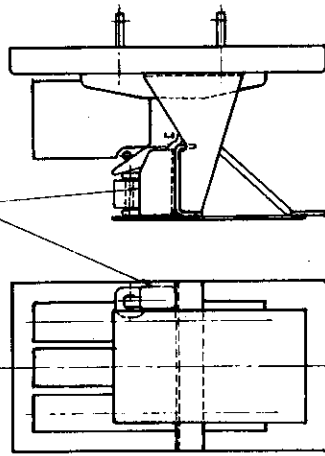
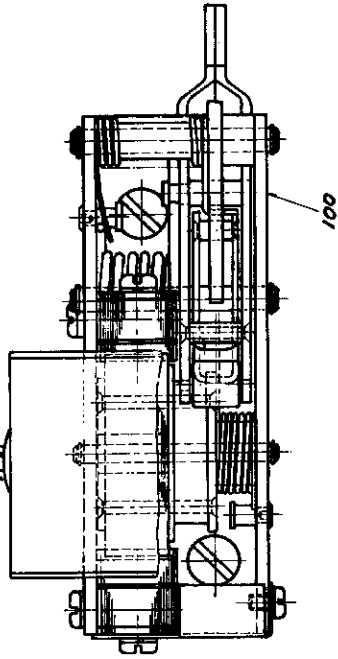

FRONT VIEW SIDE VIEW
AIR CIRCUIT BREAKER

UNDERVOLTAGE TRIP SERVICE

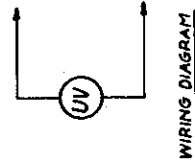

WIRING DIAGRAM

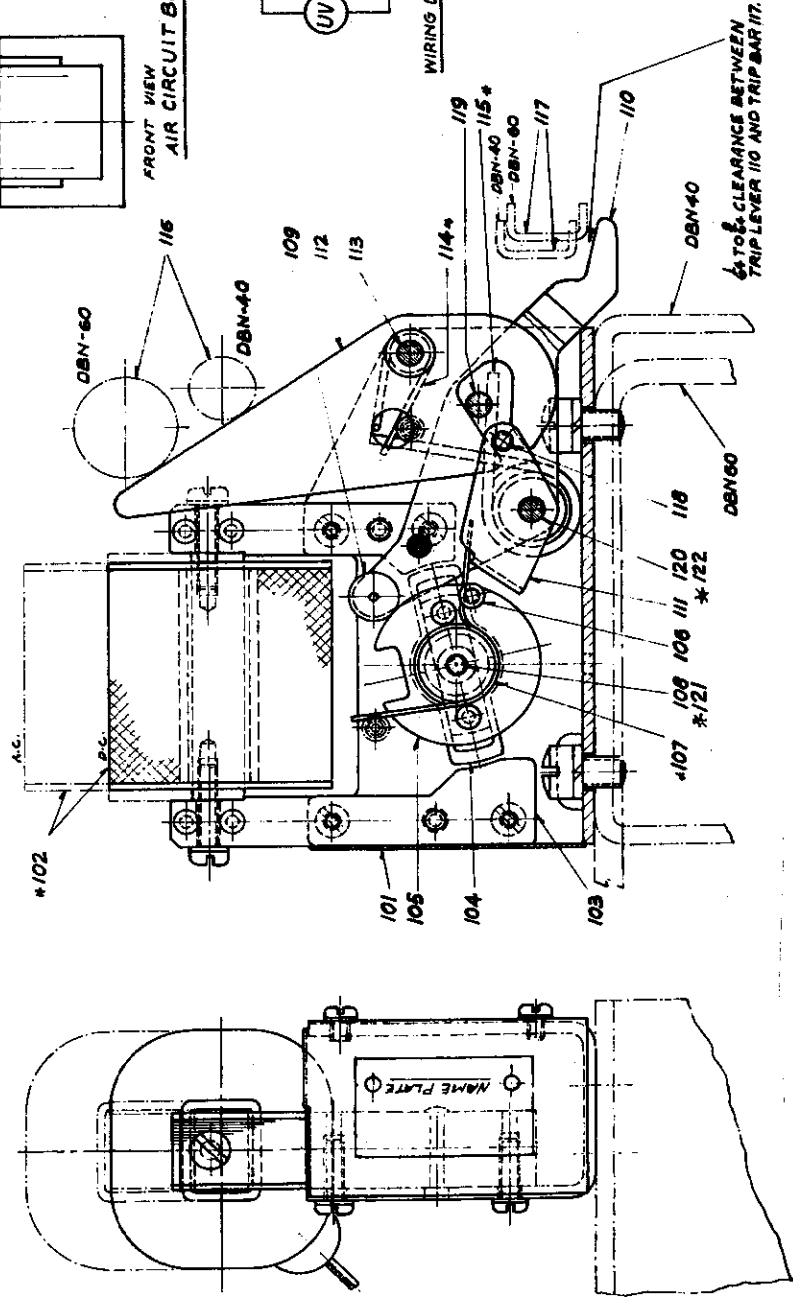

TO CLEARANCE BETWEEN TRIP LEVER 110 AND TRIP BAR 117.

REPAIR PARTS

To replace the coil (102) remove the two pan head sems machine screws and pull the coil and its core up.

To replace the armature spring (107) remove the cover (101) and also slide the coil (102) up as explained above. Then release the spring from its stop on the side of the frame and remove the truarc rings from pin (108). Push pin (108) in until it frees the armature spring and its spacer and allows them to drop out the back. Replace the spring on the spacer, hold the undervoltage trip on its side, and slide the spring and spacer in from the back until the bent end slides on to the stop on the cam (105) and over the spring release (111). Push pin (108) thru the frame and replace the truarc rings. Then with a small hook pull the other end of the spring (107) on to its stop.

To replace the reset lever spring (114) release the spring from its stops and then remove the truarc rings from pin (113) and push it out of the frame. Rotate the spring (114) clockwise and slide it off the bushing.

To replace the trip spring (115) release it from its stops and then remove the truarc ring on the end of pin (120) nearest the magnetic circuit. Push pin (120) in until the spring and its spacer are freed. Slide the spring and spacer out the front.

ADJUSTMENTS

The clearance between trip lever (110) and circuit breaker (117) is not adjustable but should be as shown on drawing.

DATA

1. Requirements of circuit breaker specification MIL-C-17587 apply
2. Qualification and shock test covered by Westinghouse Report T-122156 of 22 December 1956 and approved by BuShips Letter NObs 66853 (560K) SER 560-31768 of 22 January 1957
3. Westinghouse Drawing #900J075; BuShips #3,306,610 is the applicable master drawing